

# GAJCladding H-Shield

INSTALLATION MANUAL - v2.0



**GAJ CLADDING**

FOCUSED FOR OVER 20 YEARS

# Contents

Introduction .....	2
About GAJCladding H-Shield .....	2
Advantages of GAJCladding H-Shield .....	2
Inspection, Proper Handling and Storage.....	3
Product Inspection .....	3
Storage.....	3
Proper Handling .....	4
Forklift .....	4
Basics.....	5
Panel Cutting.....	5
Overview Panel Sizes .....	6
Panel Technical Data .....	6
Panel Edge Profile .....	7
Edge Treatment & Cleaning .....	7
Apply GAJCladding Edge Sealant.....	7
Metal Support.....	8
System Components .....	8
GAJCladding H-Shield Horizontal Clip .....	8
GAJCladding H-Shield Starter Track.....	9
GAJCladding Joint Strip .....	9
H-Shield C-Profile Extrusion and Clip Fastener .....	9
Attachment System .....	10
Panel Joints.....	11
Special Locations .....	13
Panel Layout on Facade .....	17
Bottom-up Installation.....	17
Remarks.....	18

# Introduction

## About GAJCladding H-Shield

H-Shield panel system provides you with the GAJCladding unique top-quality fiber cement specific industry coating and finishes on fiber cement board that are ideal for high-end and aesthetic façade solutions, modern and designer arrangements, and top-level exterior architectures. The system uses hidden clips to attach the panels. Let yourself be inspired by our products and present your vision through our endless variations of this single material.

## Advantages of GAJCladding H-Shield

- Maximum protection against weather
- Excellent longevity, 30 years of decoration life and 15 years of finish warranty
- Light weight and easy for on-site application, and easy installation in any climate
- Almost no maintenance is required.
- High quality panel finishes in strictly controlled environment assure no color fading or coat peeling off.
- High sustainability
- Noncombustible

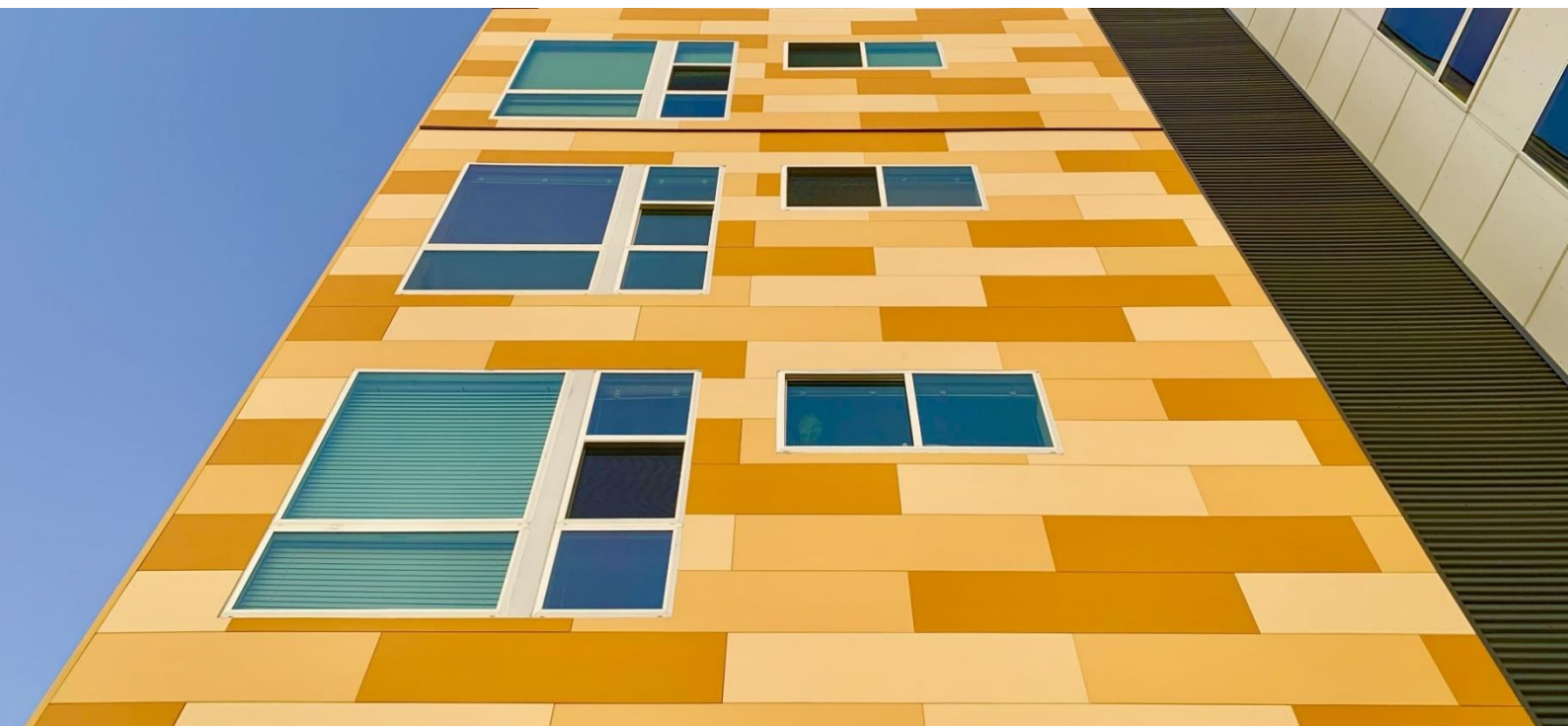

# Inspection, Proper Handling and Storage

## Product Inspection

Please carefully inspect all products before installation, whether they are damaged during transportation or have irregular surface products. Should you have a question or problem with your order, contact your local dealer or GAJCladding Customer Service.

## Storage

GAJCladding Panels products are delivered with on the pallet. Hereafter the pallets should be kept under a roof, protected from rainfall, direct sunlight, and other weather influences. If the panel is stored outside, it should be protected with an additional waterproof covering. Any panel to be installed must be kept dry.

GAJCladding Panels must be stored on a flat and dry level surface on pallets or sleepers with a minimum distance of 30cm between the stacks on all sides, leaving the possibility of ventilation around the panels. Maximum 5 pallets in a stack at the warehouse and maximum 2 pallets in a stack on the building site. Each stack should not be more than 1000 mm high. Use foam protection layer between the panels.

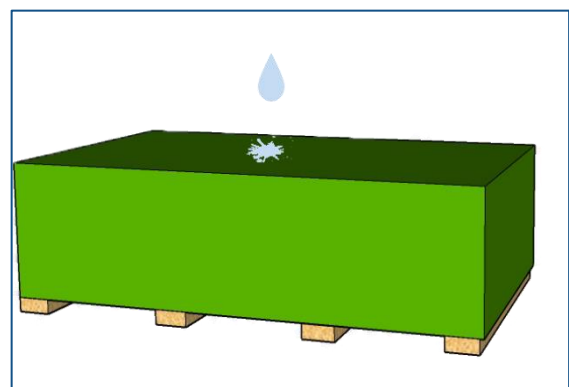
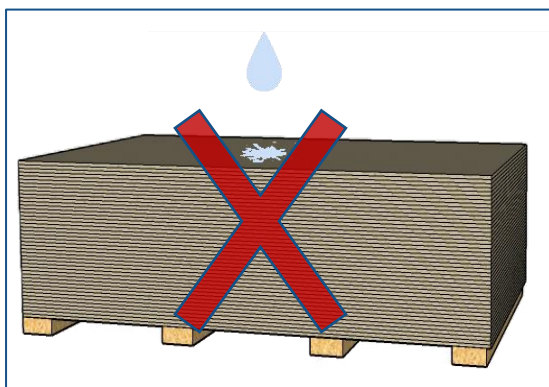

It is recommended to organize the pallets of the pre-cut and pre-drilled panels according to their sequences marked by the manufacturer or prefabricator in order to make the installation more efficient.

## Proper Handling

Always lift panels off each other by two persons, and do NOT slide them over one another to avoid scratches and damages of the panel surface. To carry the panels, always lift up them vertically and handle their edges by two persons, avoid handling them with panel flat side from facing up or down, as this can result in cracks in the panel. Do NOT draw or drag a panel over or under the next panel, as this operation will cause scratches and damage on the surface. Please note that the damaged panels caused by such operation will not be in the manufacturer's warranty.

## Forklift

Fork length must support the pallet entirely; if required, use fork extensions.



# Basics

## Panel Cutting

All GAJCladding H-Shield panels can be cut using a circular saw, or a jigsaw equipped with a diamond tipped blade. The panel can also be cut by a hand tool or a stationary device.

Note 1: When using fast running tools, dust exhaustion must be employed.

Note 2: When using hand tools, cut the panels backside up. When using stationary saw equipment, cut the panels front-side up (the saw blade must always attack the board from the front-side).

Note 3: One panel is cut at one time.

Note 4: Cutting depth should be beyond the panel thickness.

Note 5: When the panel is cut on-site for the openings such as windows, doors, pipes, etc., the edge tailored requires to be cut with slots for the clips and then sealed with the fiber cement sealant. The measurements of slot to be cut are shown as following diagrams:

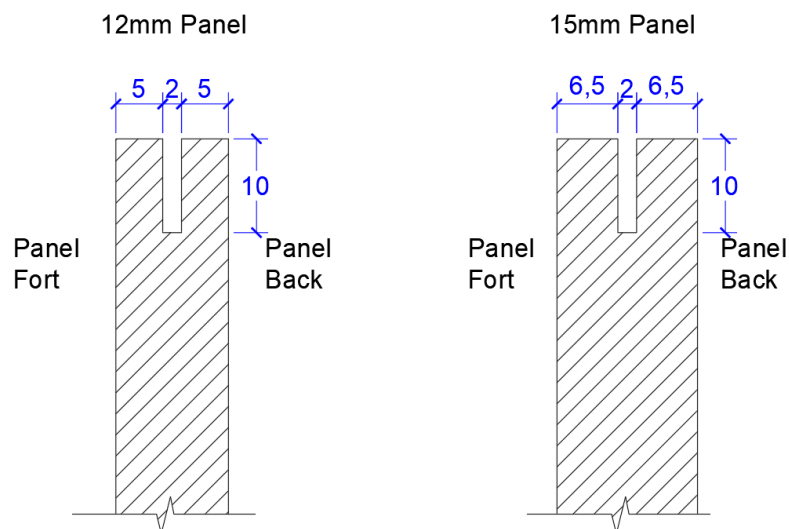

All size measures in mm



## Overview Panel Sizes

Panel Size (Width x Length x Thickness):

400x2440x12mm      400x2440x15mm  
 600x2440x12mm      600x2440x15mm  
 800x2440x12mm      800x2440x15mm

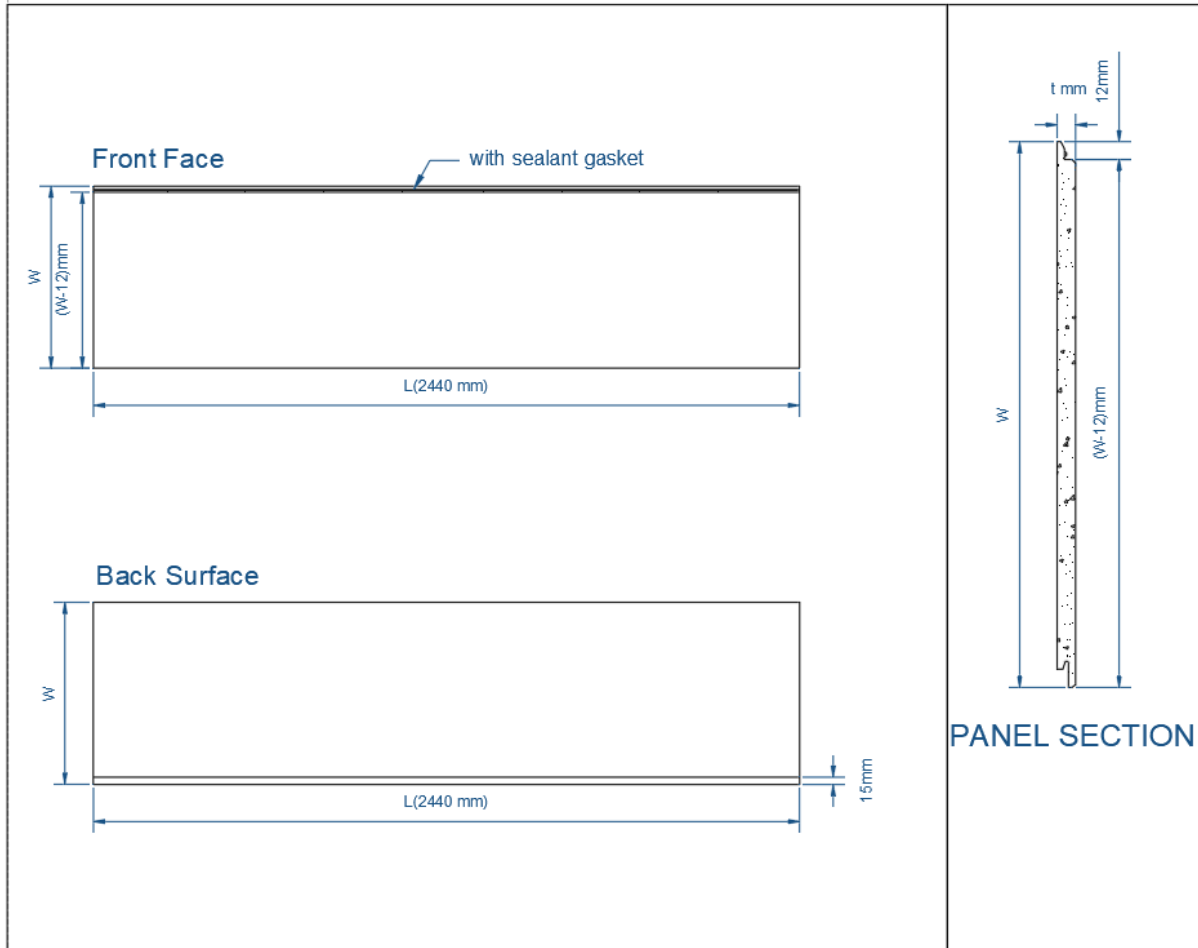

## Panel Technical Data

Properties		Text Value	
Density		1.47g/cm <sup>3</sup>	1.57g/cm <sup>3</sup>
Flexural Strength (Equilibrium Conditioning)		18.7MPa	23.2MPa
Flexural Strength (Wet Conditioning)		13.2MPa	16.5MPa
100 Freeze-Thaw Cycles Resistance	Physical Observations	Pass	
	Flexural Strength Retention Rate	84.5%	
50 Soak/Dry Cycles Performance		97%	
Falling Ball Impact		Pass (10J)	
Non-Combustibility		Class A	

## Panel Edge Profile

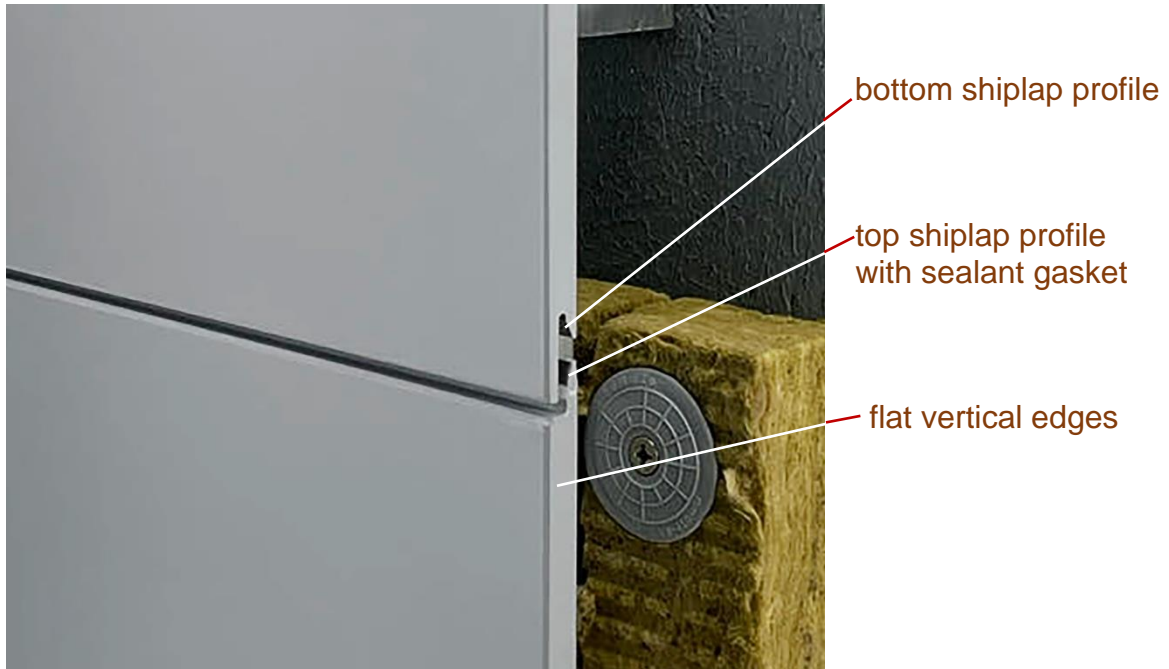

## Edge Treatment & Cleaning

After cutting the panel, the cut edges should be sanded and sealed with fiber cement edge sealant. This reduces the possibility of damage and improves panel edge performance.

Remove dust caused by panel cutting and drilling from the front side and backside of the panels with a soft brush/duster or a vacuum cleaner.

## Apply GAJCladding Edge Sealant

Apply edge sealant simply run applicator along panel edges and holes. Ensure full coverage of edges and holes. Repeat this application if necessary.



# Metal Support

## System Components

### 1. Systems with external insulation

1. Exterior Wall
2. Vapor Barrier & Waterproof
3. Brackets
4. Exterior Thermal Insulation
5. Vertical Rail
6. H-Shield Clip
7. GAJCladding H-Shield Panel
8. Weatherproof Sealant & Joint Strip

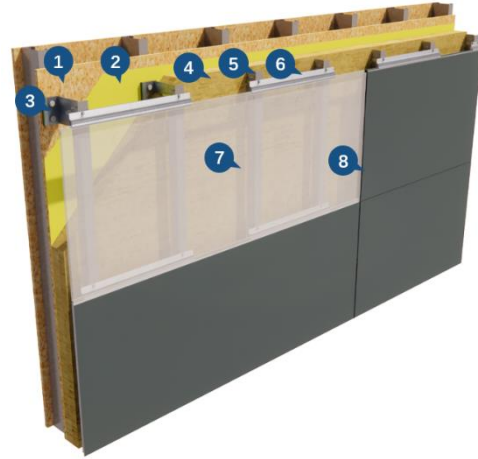

### 2. Systems without external insulation

1. Structural Stud
2. Sheathing & Vapor Barrier
3. H-Shield Clip
4. GAJCladding H-Shield Panel
5. Weatherproof Sealant & Joint Strip

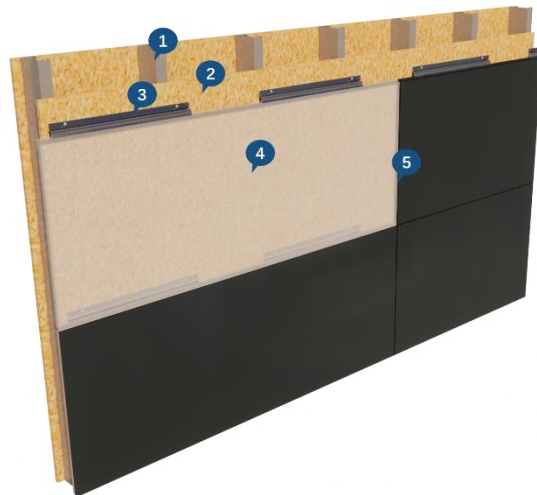

## GAJCladding H-Shield Horizontal Clip

H-Shield Horizontal Clip Length 508mm

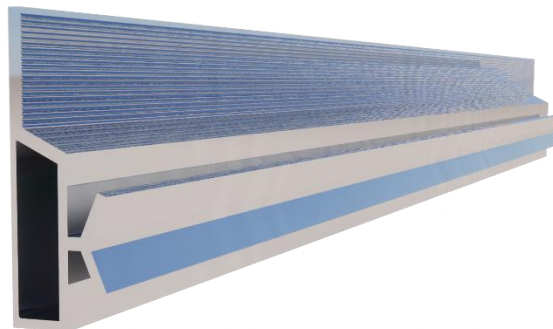

## GAJCladding H-Shield Starter Track

H-Shield Starter Track Length 2400mm

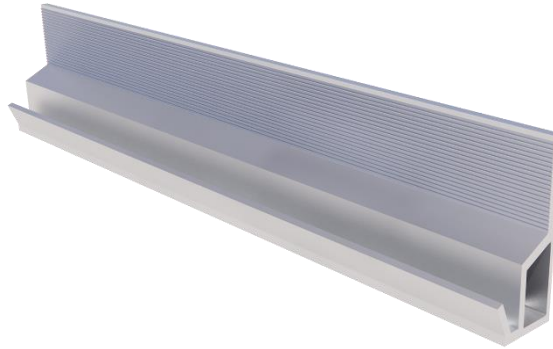

## GAJCladding Joint Strip

Joint Strip to be installed between the vertical panel joints, foam strip can also be used instead.

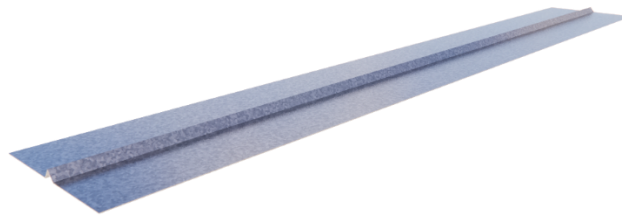

## H-Shield Vertical Rail and Clip Fastener

### 1. Vertical Rail:

For aluminum material: Minimum Profile Thickness  $\geq 2.5\text{mm}$ .

For Galvanized/Stainless Steel material: Minimum Profile Thickness  $\geq 1.2\text{mm}$ .

### 2. Clip Fastener

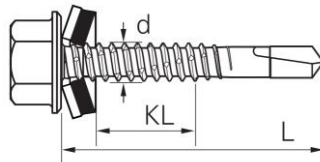

Material: Galvanized/Stainless Steel.

Minimum size: M4.8 x 19,  $d \geq 4.8\text{mm}$ ,  $L \geq 19\text{mm}$ .

## Attachment System

### Systems with external insulation

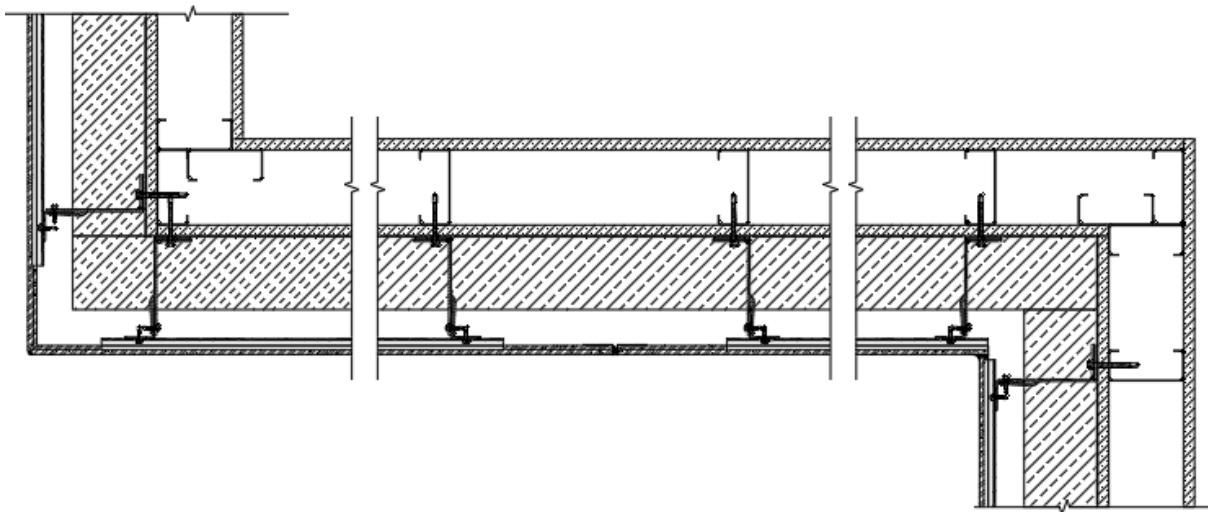

### Systems without external insulation

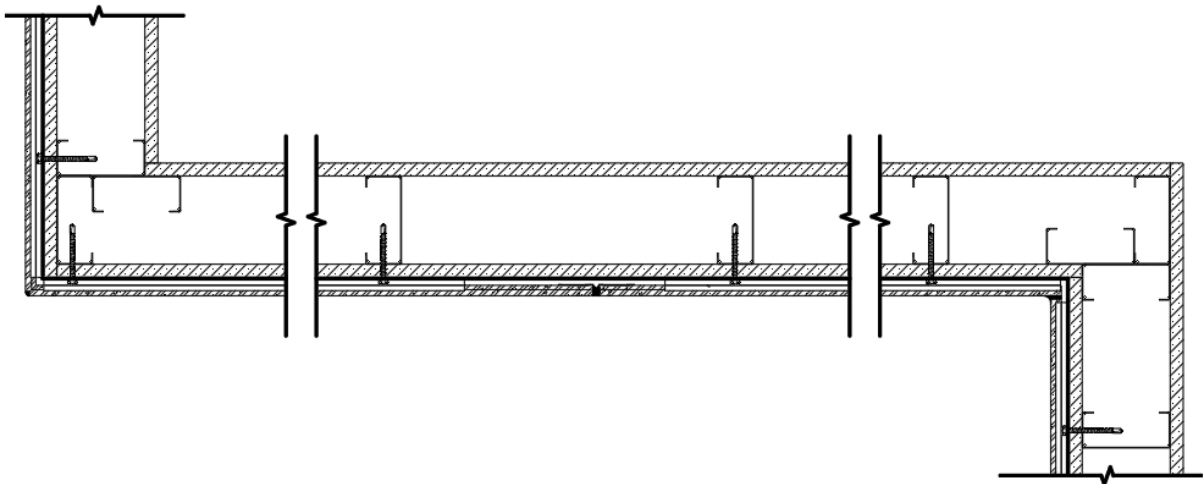

### Use GAJCladding H-Shield Clips

Use GAJCladding manufactured clips specifically designed for H-Shield panels to secure the panels.

Each H-Shield Clip should be fixed with a minimum of two screws and should be fixed to Structural Stud or Vertical Extrusion.

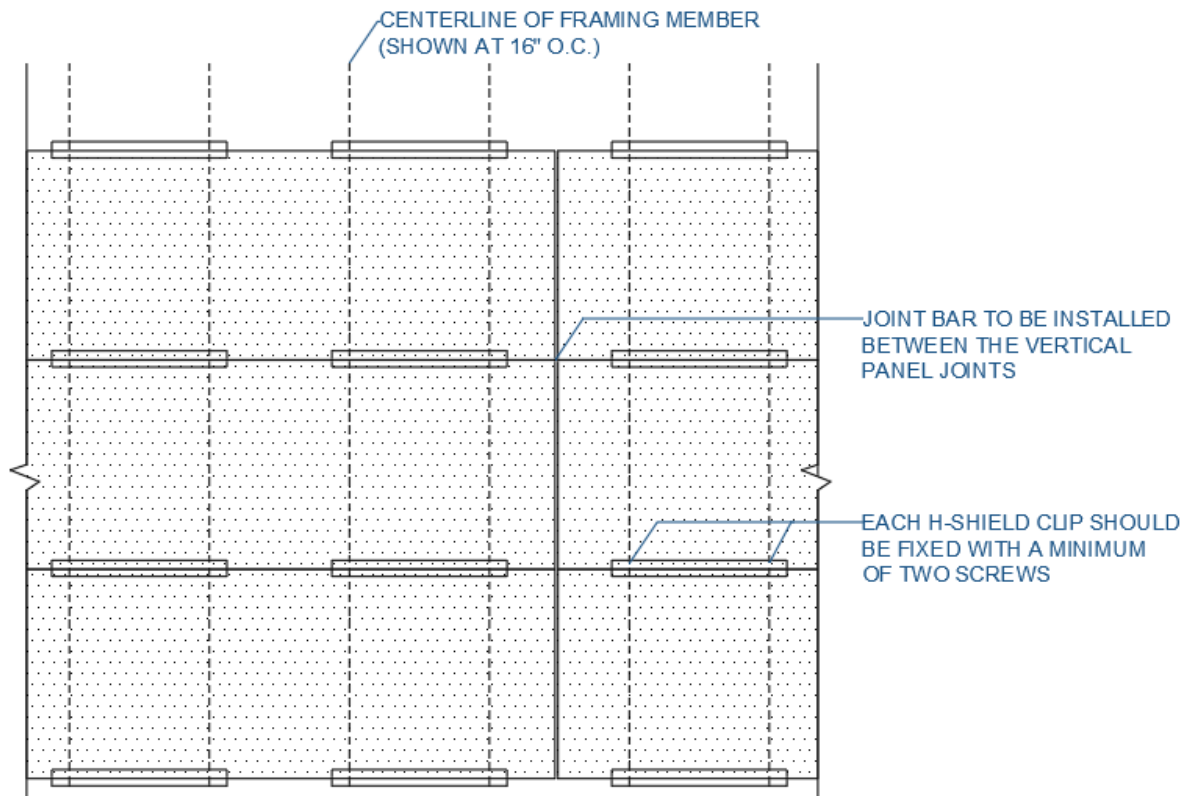

## Panel Joints

Horizontal panel joints shall not be filled with weatherproof sealant. They are usually backed with horizontal supporting rails and kept open for the air flow. However, the vertical panel joints shall be filled with weatherproof sealant.



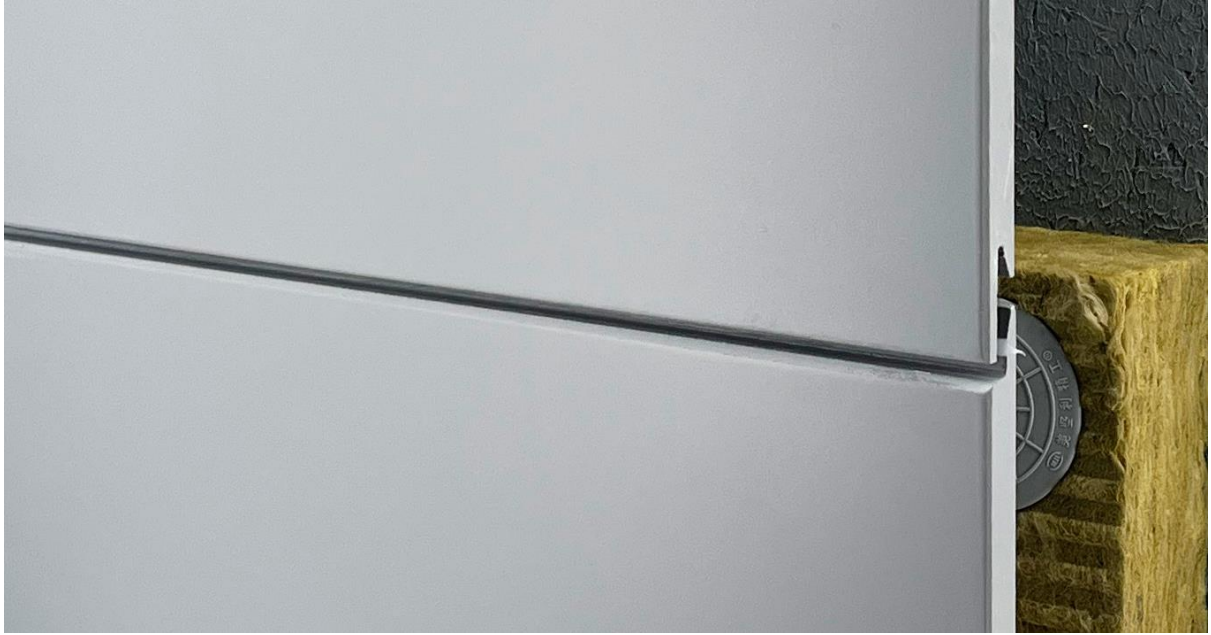

# Special Locations

## Systems with external insulation

Horizontal Joint Detail:

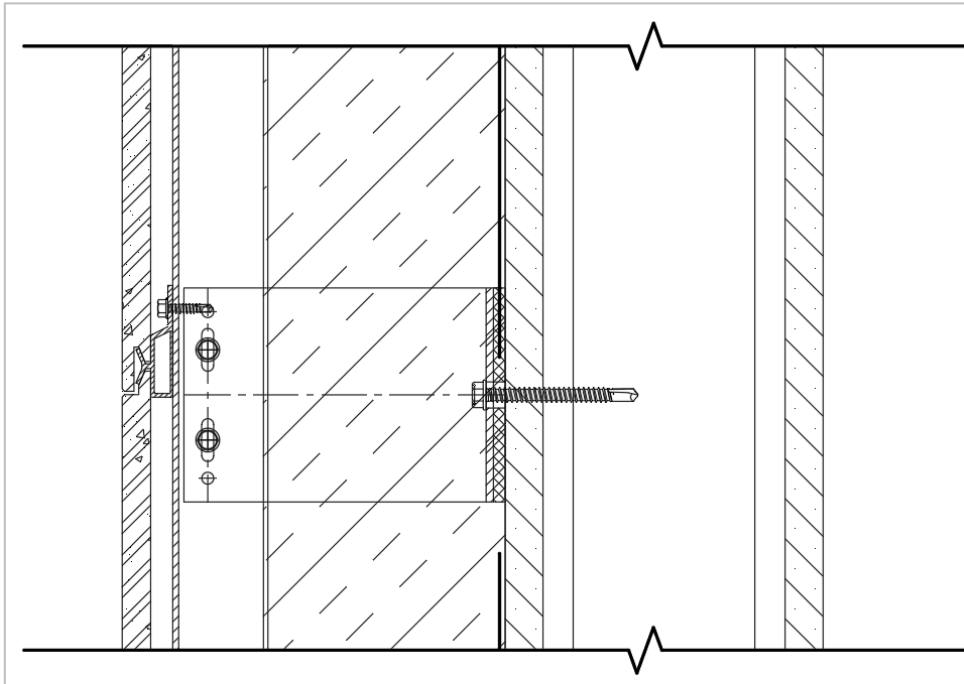

Vertical Joint Detail:

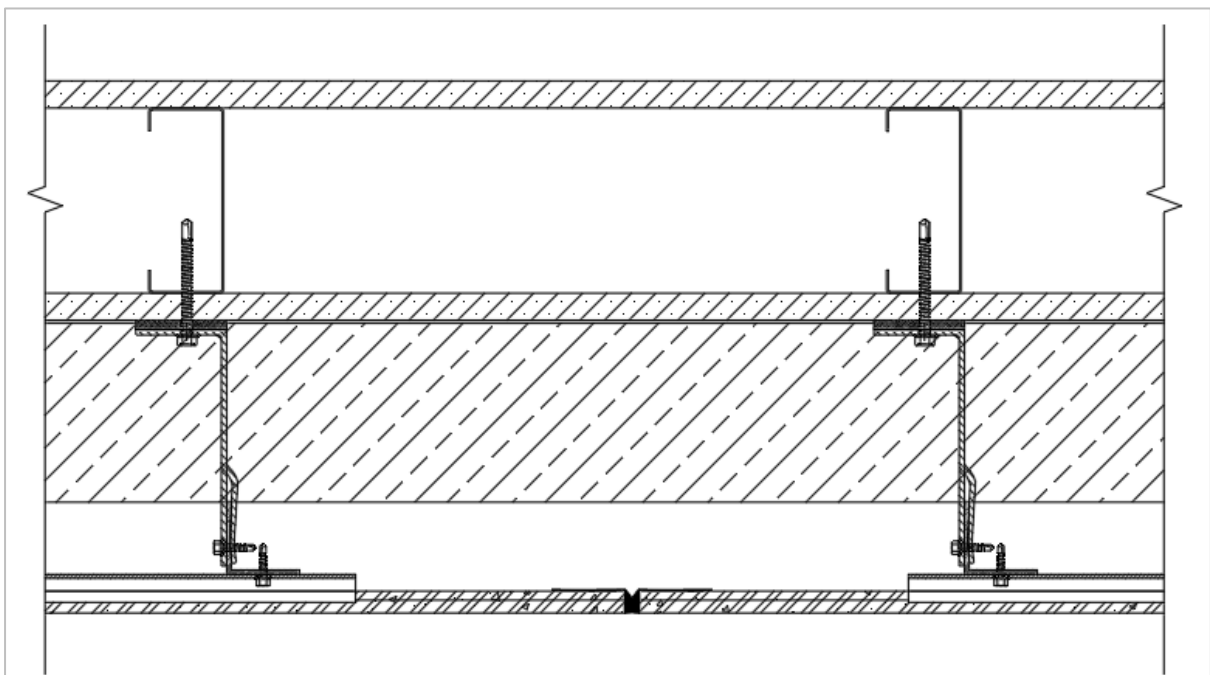



Outer Corner:

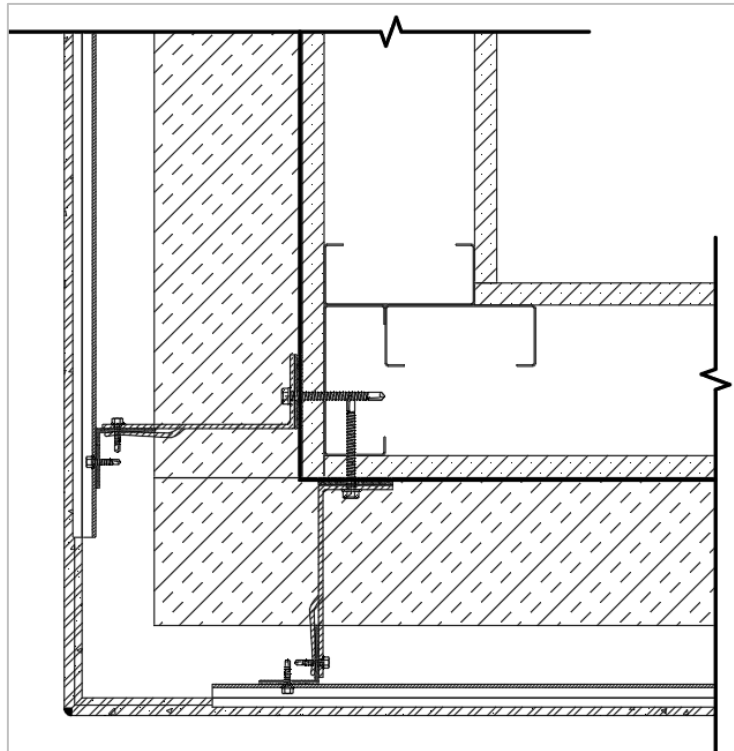

Inner Corner:

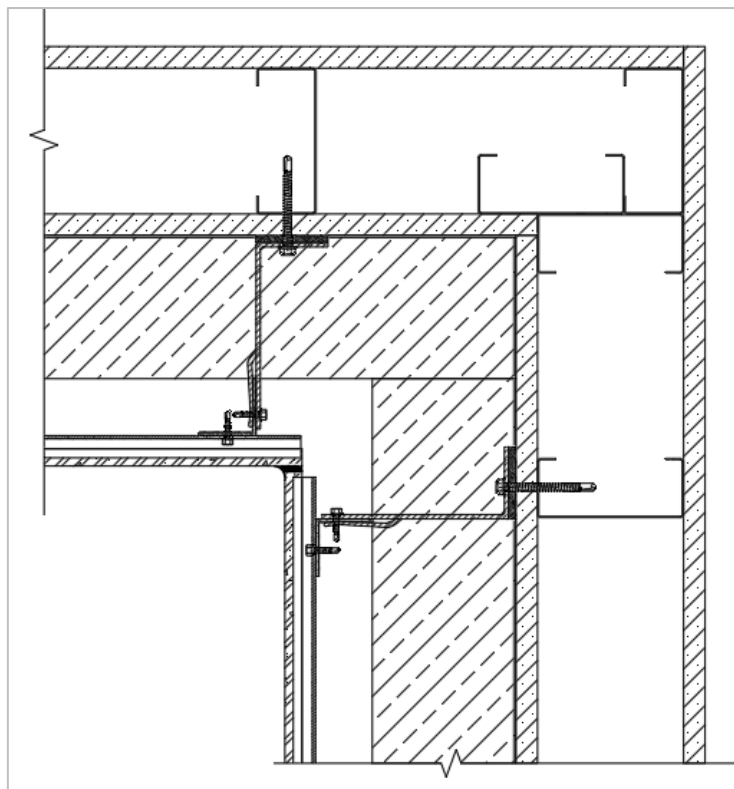

## Systems without external insulation

Horizontal Joint Detail:

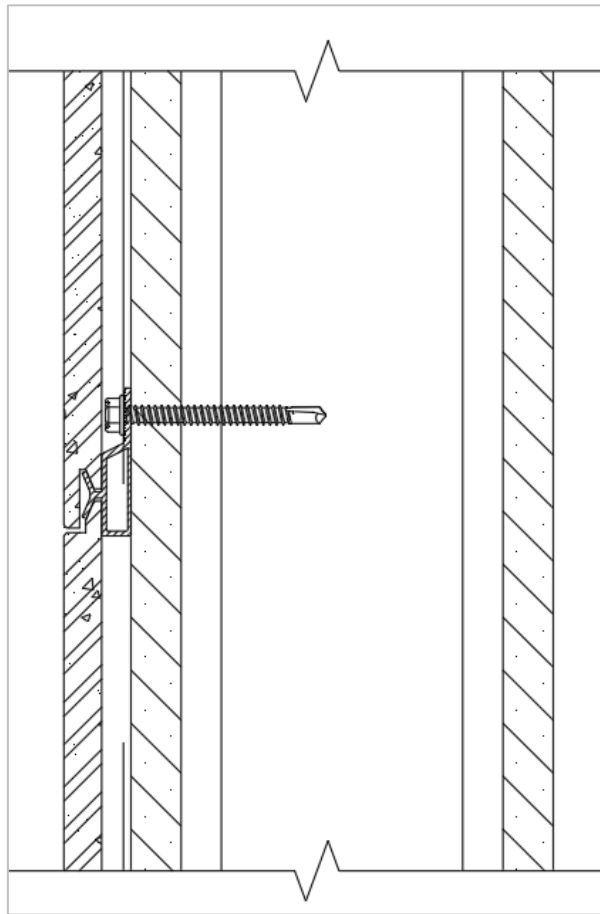

Vertical Joint Detail:

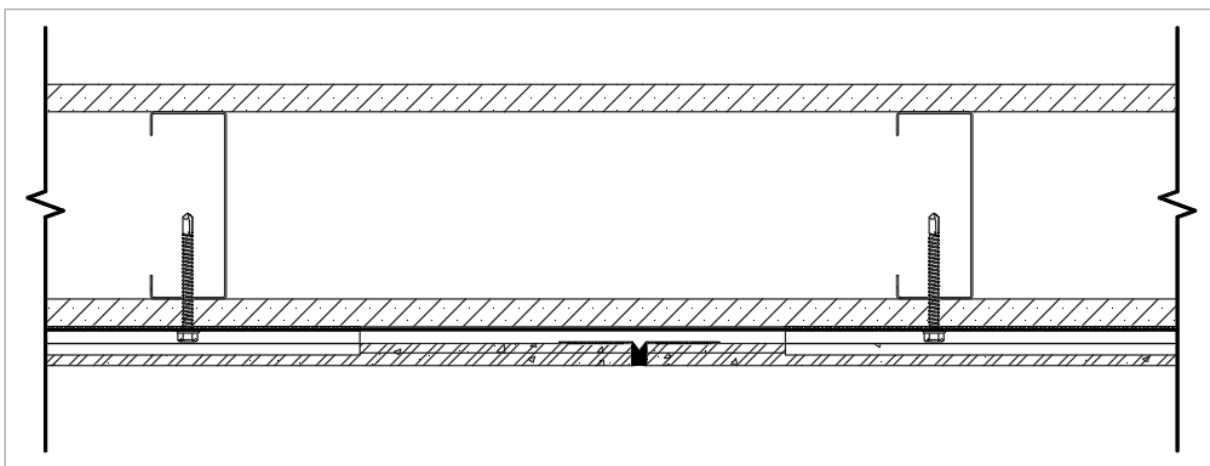

Outer Corner:

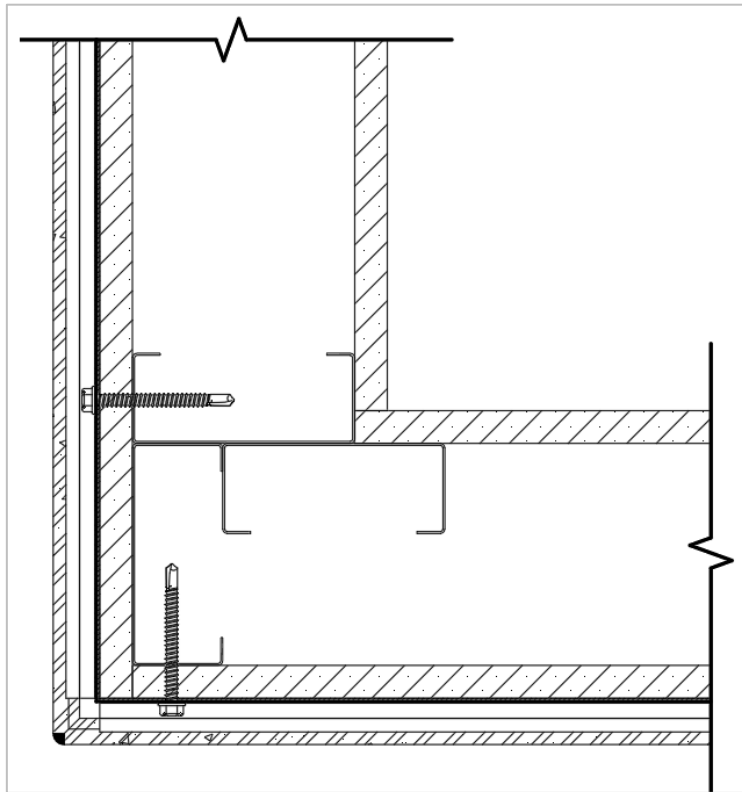

Inner Corner:

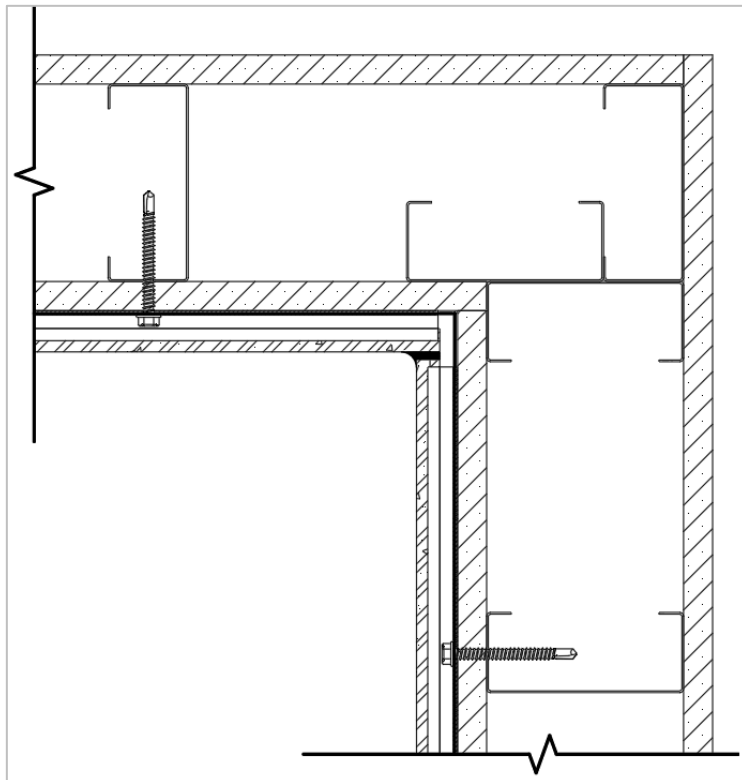

## Panel Layout on Facade

GAJCladding H-Shield panels are designed for horizontal mounting on the façade wall. However, if the architect wishes to change the panel layout into a vertical mounting, the special clips shall be customized and used.

## Bottom-up Installation

Major steps of working bottom-up approach are as follows:

Step 1. Measure the façade wall from bottom up, mark the lines for each panel's bottom position.

Step 2. Install the vertical supporting frames and fasten the clips with the number required.

Step 3. Place the panel on the clips, then adjust the position horizontally.

Step 4. Place the clips on the top edge of the panel and adjust the panel flatness against the façade wall surface.

Step 5. Repeat the previous steps. Make sure the vertical gaps between two panels are between 6~12mm.

Step 6. After completing the amounting panels, start taping the panel's vertical edges to prepare for the weatherproof sealant caulking.

Step 3. Remove tapes and clean up.

## Remarks

### Cleaning

There are two methods of cleaning panels, mechanical cleaning and chemical cleaning. In principle, perform the cleaning of the panel over the entire surface, because partial cleaning can result in color and tonal imbalance. Normal stains can be removed with a sponge and water. Warning High Pressure Cleaning is a rough treatment of panel. Use of a high-pressure cleaner may damage the surface. Therefore, high pressure cleaning is not recommended.

### Impact by Pollution and Nature

Weather and nearby vegetation may affect the appearance of the panels. Take caution to avoid pollution, dust and leaves from trees, bushes and flowers to not impact the integrity of the panels. Excessive humidity, salts, or other chemical agents can corrode the panel and attack metal.

### Special Information

THE INFORMATION OR DATA IN THIS SHEET SERVES TO ENSURE THE PRODUCT'S INTENDED PURPOSE OR ITS SUITABILITY FOR USE AND IS BASED ON OUR FINDINGS AND EXPERIENCE. NEVERTHELESS, USERS ARE RESPONSIBLE FOR ESTABLISHING THE SUITABILITY OF THE PRODUCT FOR ITS INTENDED USE. APPLICATIONS OTHER THAN THOSE EXPLICITLY MENTIONED IN THIS TECHNICAL DATA SHEET ARE ONLY PERMISSIBLE AFTER PRIOR CONSULTATION WITH CHONGQING GUANJIE QIZHONG BUILDING MATERIALS CO., LTD. WHERE NO APPROVAL IS GIVEN, SUCH APPLICATIONS ARE AT THE RISK OF THE USER. THIS APPLIES IN PARTICULAR WHEN THE PRODUCT IS USED IN COMBINATION WITH OTHER PRODUCTS. WHEN A NEW TECHNICAL DATA SHEET IS PUBLISHED, ALL PREVIOUS TECHNICAL DATA SHEETS ARE NO LONGER VALID. THE LATEST VERSION IS AVAILABLE ON THE INTERNET AT [WWW.GAJCLADDING.COM](http://WWW.GAJCLADDING.COM).

# GAJCladding H-Shield INSTALLATION MANUAL

July 21, 2024



**GAJ CLADDING**

*FOCUSED FOR OVER 20 YEARS*

Chongqing Guanjie Qizhong Building Materials Co., Ltd.

[info@gajcladding.com](mailto:info@gajcladding.com)

[www.gajcladding.com](http://www.gajcladding.com)