

GAJCladding CladForm

GC2 System Architecture Detail - v2.5



GAJ CLADDING

FOCUSED FOR OVER 20 YEARS

Contents

Application.....	3
Principles for Designing.....	3
Profile Specification.....	5
Construction Details.....	6
Remarks.....	19

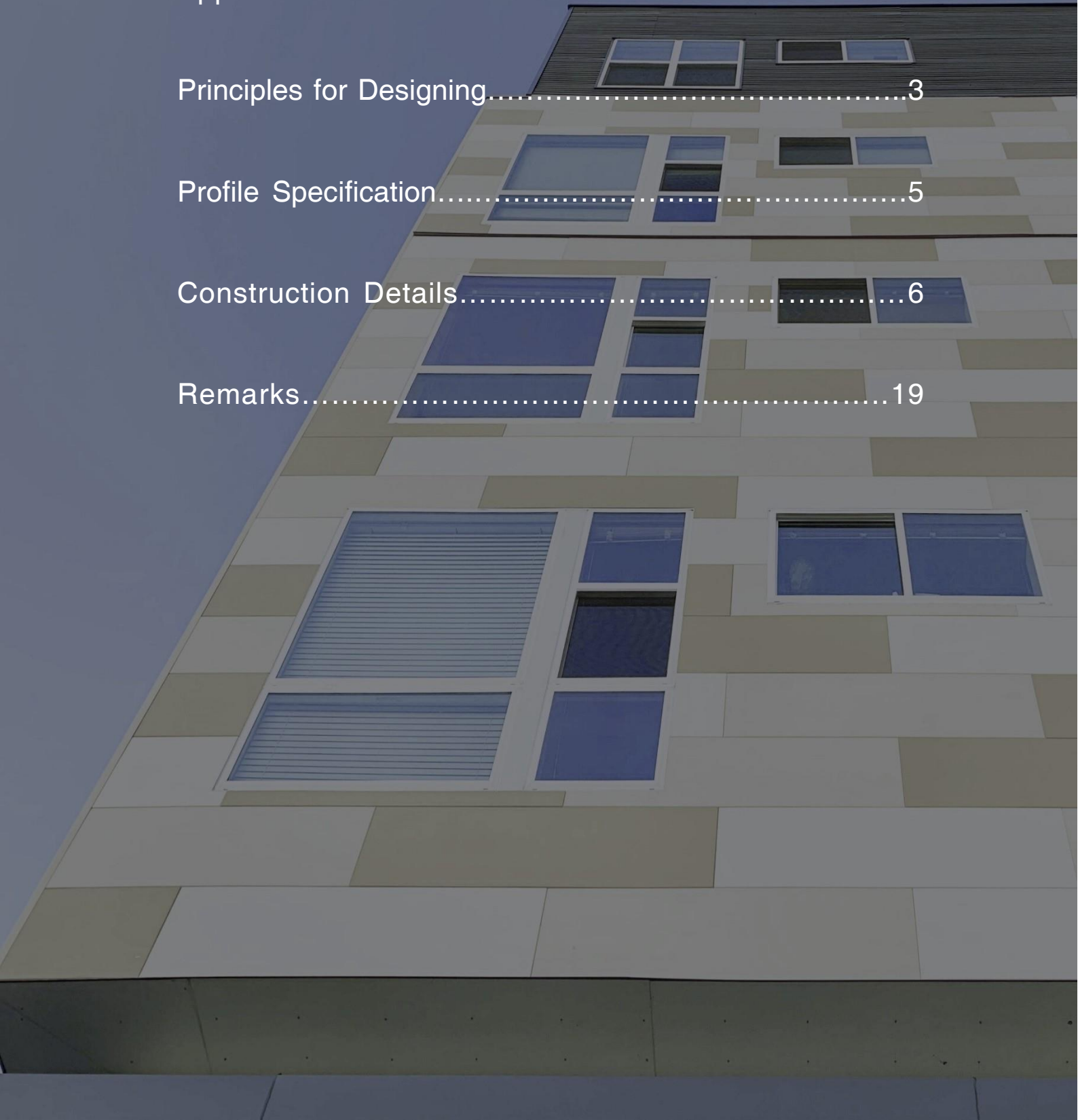

Application

This GAJCladding CladForm Panel System's Architectural Details provides a guidance on the most common details and design considerations to ensure that the construction details are suitable for the intended application of their project, consistent with industry practices in light of commercial and multifamily residential buildings.

This guide should be read along with the installation manual.

Principles for Designing

Supporting Studs and Shear Walls

Certification for the structural stability of any supporting studs should be in accordance with local building regulations and must be obtained by the building owner or official representatives, such as the project engineer. Supporting studs are used, the shear walls should be checked by the installer prior to installation to confirm that it is flat and true, and that correct fixings and details are employed. Any discrepancy should be referred to the design team.

GC2 Support System

GAJCladding GC2 Support System consists of clips, vertical rail, brackets. It combines an elegant arrangement particularly for CladForm panels. The specialized Clip matches the CladForm panels, anchor the panels onto vertical rail makes this system much simpler, more reliable and stable in its performance, and, the most important, easier for customer to cut on-site and install.

1. Exterior Wall
2. Vapor Barrier & Waterproof
3. Brackets
4. Exterior Thermal Insulation
5. Vertical Rail
6. CladForm Clip
7. CladForm Panel

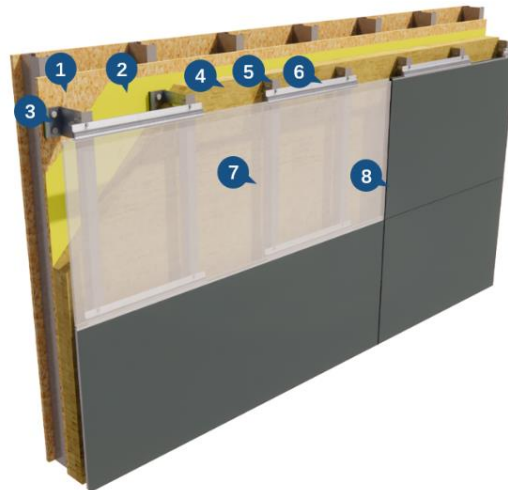

Anchors Requirements

Failure to use the clips that are GAJCladding products required may invalidate product warranty.

Weather/Water Resistant Barriers

A material used on the exterior of a building. It can resist bulk liquids that has leaked, penetrated or penetrated into the outer coating to the outer sheath or concrete wall (depending on the application) and further into the wall assembly.

Finishes

There are some different colors and textures, such as Colorshell, Fabricshell, Timbershell, etc. Each series finish color corresponds to a different level of finish textures. For more specific information, you can refer to the color catalog.

Profile Specification

It is advisable to use a vertical profile that allows for tolerance and any discrepancy in component layout and installation dimensions.

Minimum profile thickness	Aluminum	$\geq 2\text{mm}$
	Galvanised/stainless steel	$\geq 1.2\text{mm}$
Minimal depth of profile		$\geq 35\text{mm}$
Minimal width of intermediate profile		$\geq 40\text{mm}$
Maximum buckle under influence of strain		$\leq \text{Span}/250$
Safety factor calculation of strength		3
Maximum length of vertical profile		6m
Movement joints between adjacent profiles		20mm
Maximum unsupported length from last bracket/anchor		250mm

Construction Details

This chapter provides an overview of the various common details to cover a wide range of situations that are expected on a regular basis.

These drawings do not contain the complete details required for the configuration and must be read along with the installation manual at www.gajcladding.com. You should obtain architectural, engineering or other technical advice to assess whether these drawings are suitable for your particular project. Chongqing Guanjie Qizhong Building Materials Co., Ltd. is not responsible for the use of these drawings.

Figure 1: Elevation and Floor Plan.....	7
Figure 2: Vertical Joint Detail.....	8
Figure 3: Horizontal Joint Detail.....	9
Figure 4: Outer Corner Detail.....	10
Figure 5: Inner Corner Detail.....	11
Figure 6: Window Jamb Detail (Option 1).....	12
Figure 7: Window Jamb Detail (Option 2).....	13
Figure 8: Window Head Detail (Option 1)	14
Figure 9: Window Head Detail (Option 2)	15
Figure 10: Window Sill Detail	16
Figure 11: Parapet Detail	17
Figure 12: Base Detail	18

Figure 1: Elevation and Floor Plan

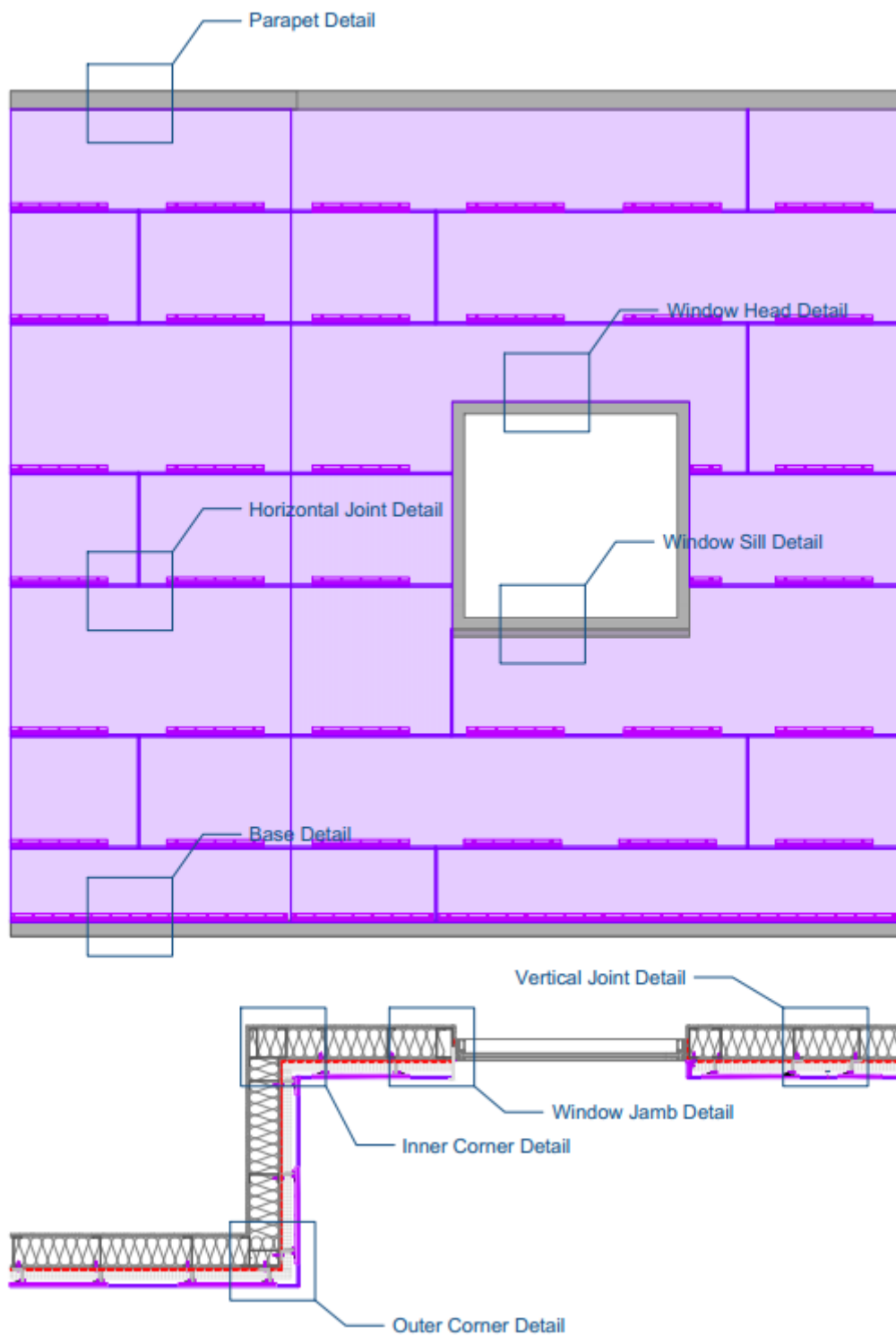
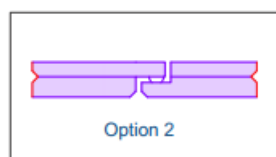
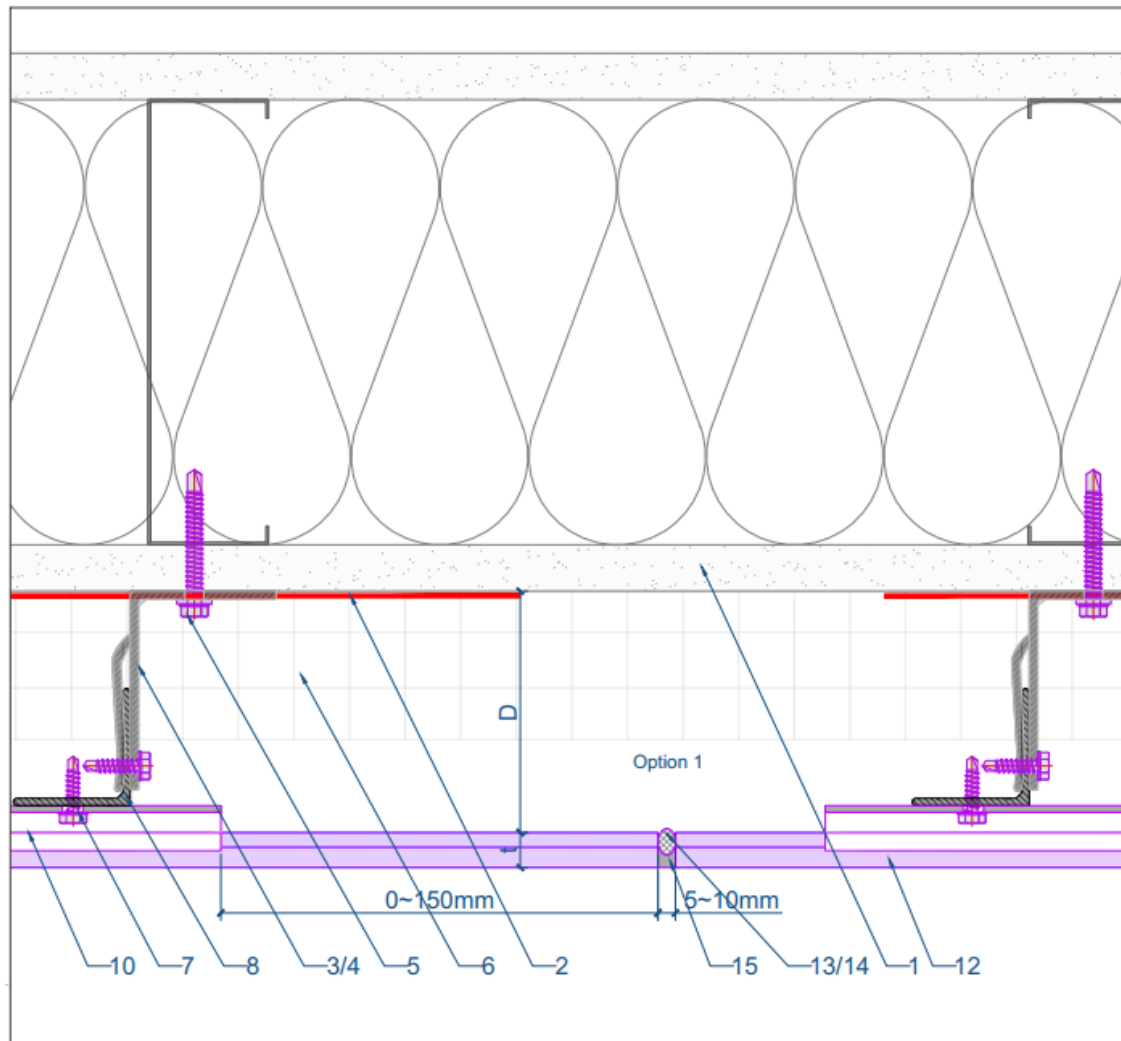

Figure 2: Vertical Joint Detail



Legend

- | | | |
|--------------------------------|------------------------|------------------------------|
| 1. Exterior Wall | 9. Aluminum Angle | 17. Jamb Closure |
| 2. Vapor Barrier | 10. Clip | 18. Window Sill |
| 3. Single Bracket | 11. Starter Track | 19. Capping |
| 4. Double Bracket | 12. CladForm Panel | 20. Self-drilling Screw M4.8 |
| 5. Substrate Fastener | 13. Joint Strip | D - System depth |
| 6. Insulation | 14. Foam Strip | t - Panel thickness |
| 7. Self-drilling Screw M4.8*19 | 15. Joint Sealant | |
| 8. L-profile Rail | 16. Perforated Closure | |

Figure 3: Horizontal Joint Detail

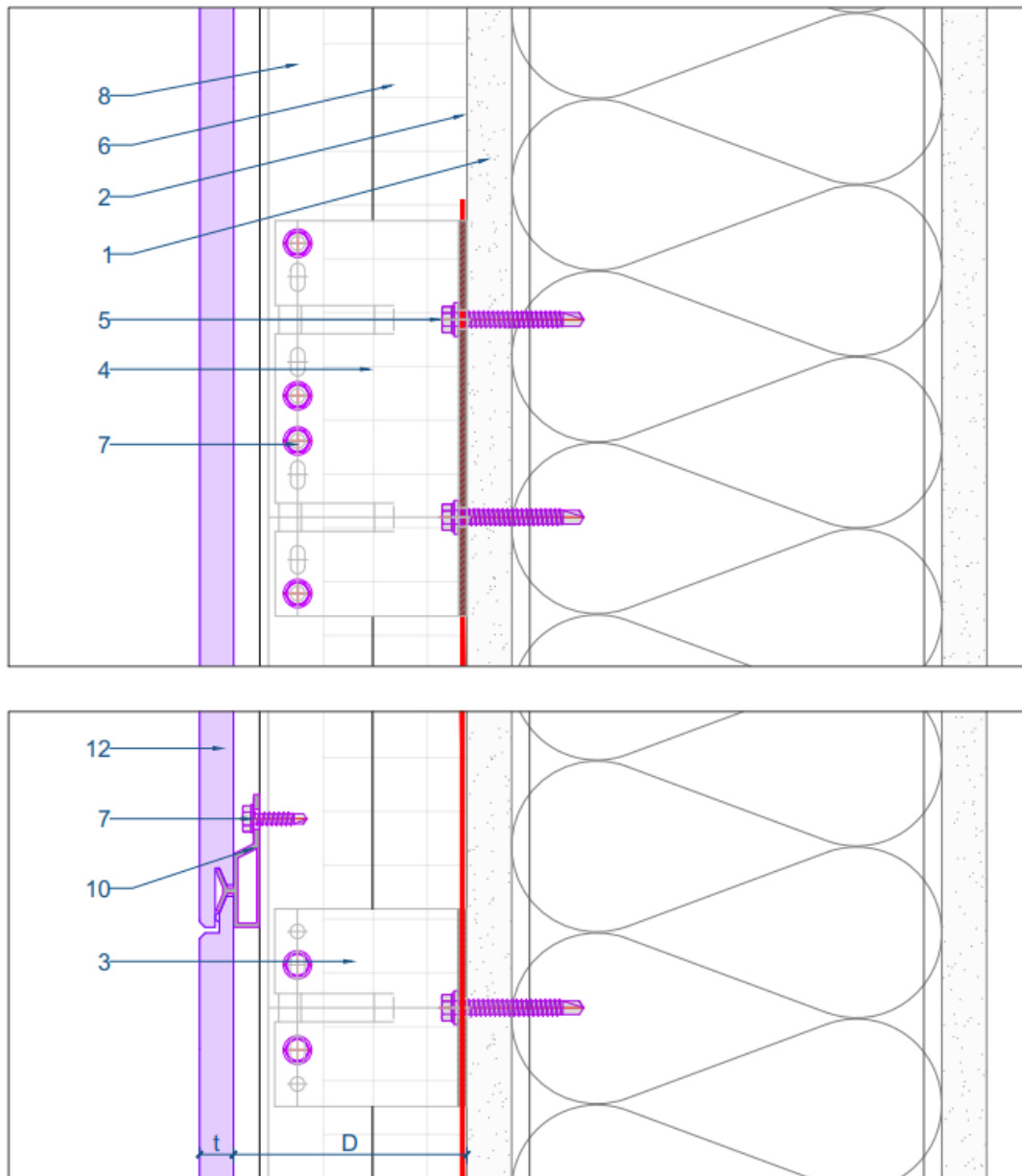

Legend

- | | | |
|--------------------------------|------------------------|------------------------------|
| 1. Exterior Wall | 9. Aluminum Angle | 17. Jamb Closure |
| 2. Vapor Barrier | 10. Clip | 18. Window Sill |
| 3. Single Bracket | 11. Starter Track | 19. Capping |
| 4. Double Bracket | 12. CladForm Panel | 20. Self-drilling Screw M4.8 |
| 5. Substrate Fastener | 13. Joint Strip | D - System depth |
| 6. Insulation | 14. Foam Strip | t - Panel thickness |
| 7. Self-drilling Screw M4.8*19 | 15. Joint Sealant | |
| 8. L-profile Rail | 16. Perforated Closure | |

Figure 4: Outer Corner Detail

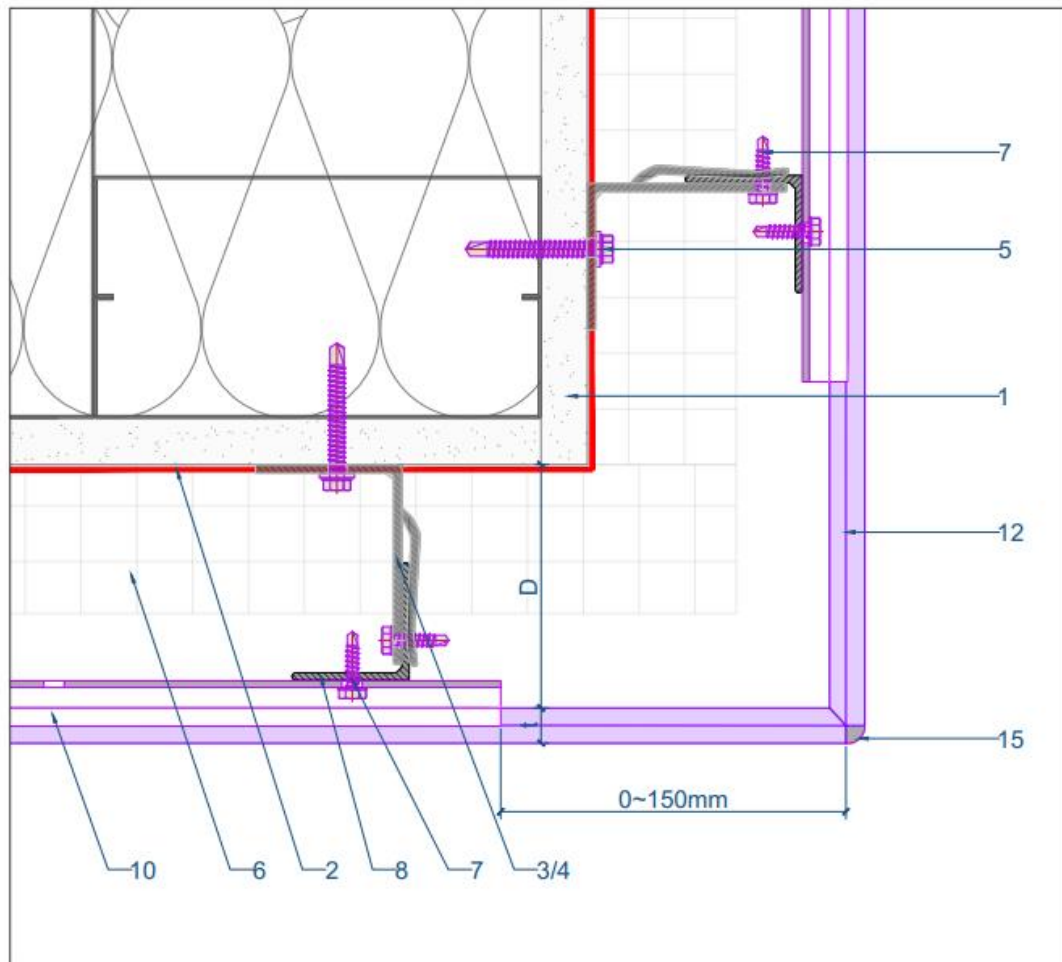

Legend

- | | | |
|--------------------------------|------------------------|------------------------------|
| 1. Exterior Wall | 9. Aluminum Angle | 17. Jamb Closure |
| 2. Vapor Barrier | 10. Clip | 18. Window Sill |
| 3. Single Bracket | 11. Starter Track | 19. Capping |
| 4. Double Bracket | 12. CladForm Panel | 20. Self-drilling Screw M4.8 |
| 5. Substrate Fastener | 13. Joint Strip | D - System depth |
| 6. Insulation | 14. Foam Strip | t - Panel thickness |
| 7. Self-drilling Screw M4.8*19 | 15. Joint Sealant | |
| 8. L-profile Rail | 16. Perforated Closure | |

Figure 5: Inner Corner Detail

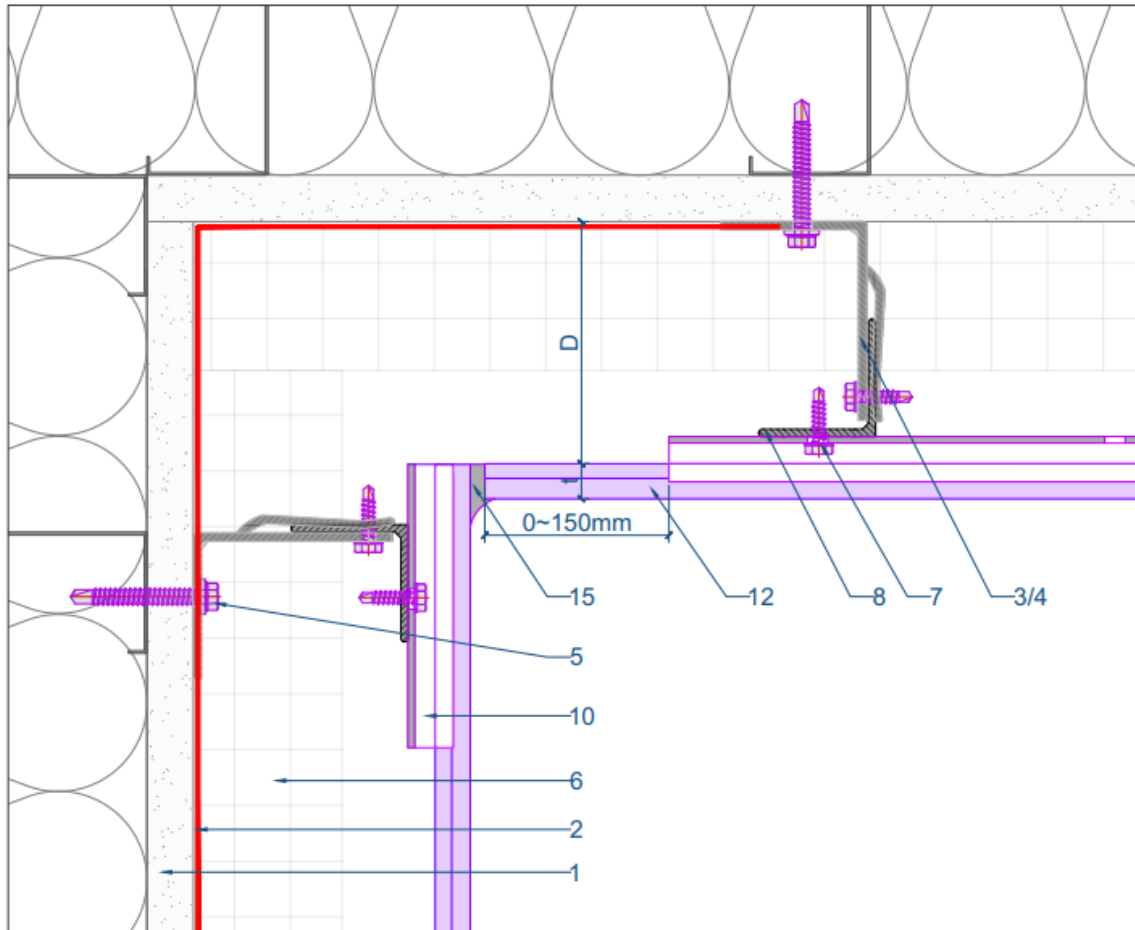

Legend

- | | | |
|--------------------------------|------------------------|------------------------------|
| 1. Exterior Wall | 9. Aluminum Angle | 17. Jamb Closure |
| 2. Vapor Barrier | 10. Clip | 18. Window Sill |
| 3. Single Bracket | 11. Starter Track | 19. Capping |
| 4. Double Bracket | 12. CladForm Panel | 20. Self-drilling Screw M4.8 |
| 5. Substrate Fastener | 13. Joint Strip | D - System depth |
| 6. Insulation | 14. Foam Strip | t - Panel thickness |
| 7. Self-drilling Screw M4.8*19 | 15. Joint Sealant | |
| 8. L-profile Rail | 16. Perforated Closure | |

Figure 6: Window Jamb Detail (Option 1)

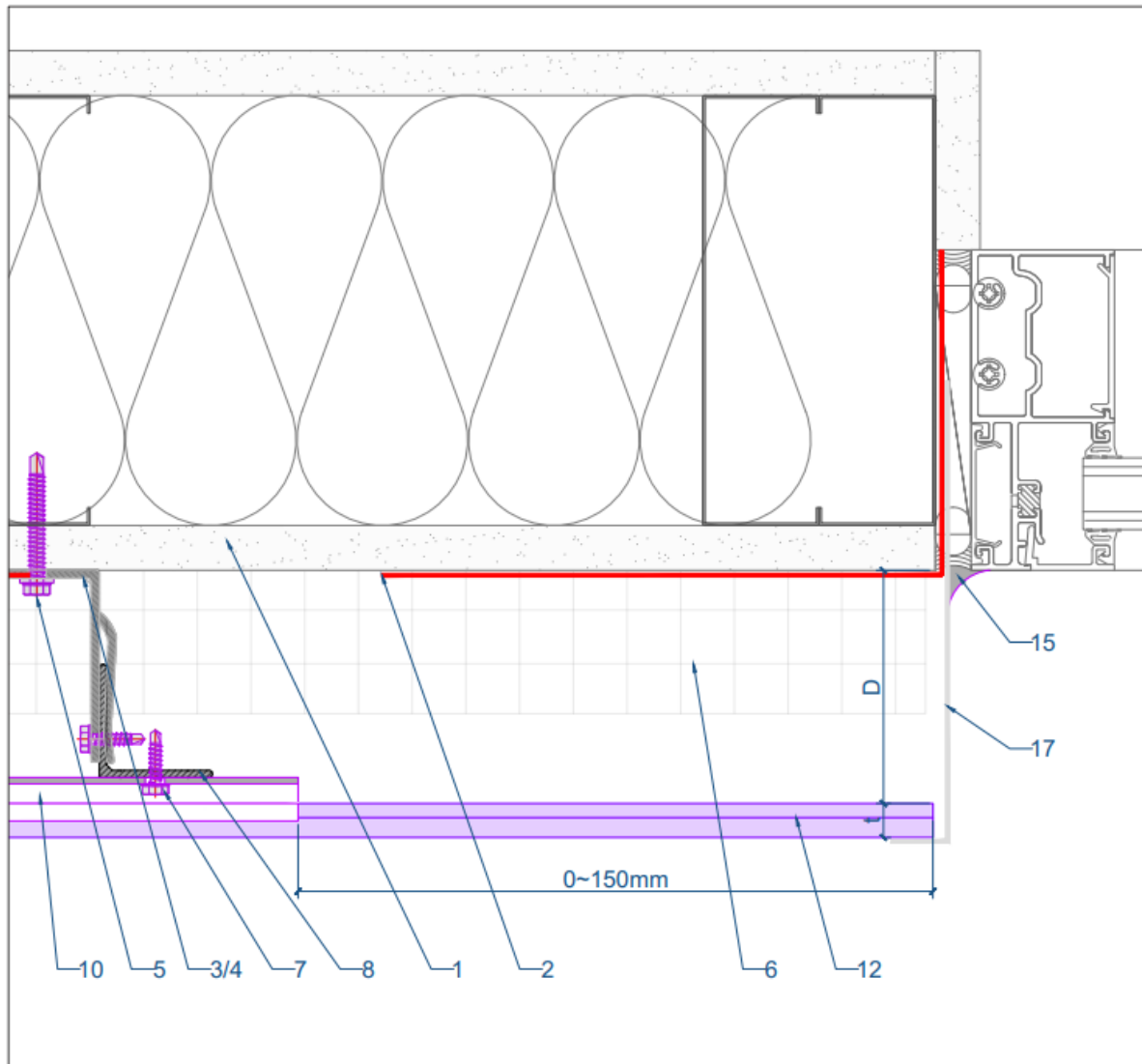

Legend

- | | | |
|--------------------------------|------------------------|------------------------------|
| 1. Exterior Wall | 9. Aluminum Angle | 17. Jamb Closure |
| 2. Vapor Barrier | 10. Clip | 18. Window Sill |
| 3. Single Bracket | 11. Starter Track | 19. Capping |
| 4. Double Bracket | 12. CladForm Panel | 20. Self-drilling Screw M4.8 |
| 5. Substrate Fastener | 13. Joint Strip | D - System depth |
| 6. Insulation | 14. Foam Strip | t - Panel thickness |
| 7. Self-drilling Screw M4.8*19 | 15. Joint Sealant | |
| 8. L-profile Rail | 16. Perforated Closure | |

Figure 7: Window Jamb Detail (Option 2)

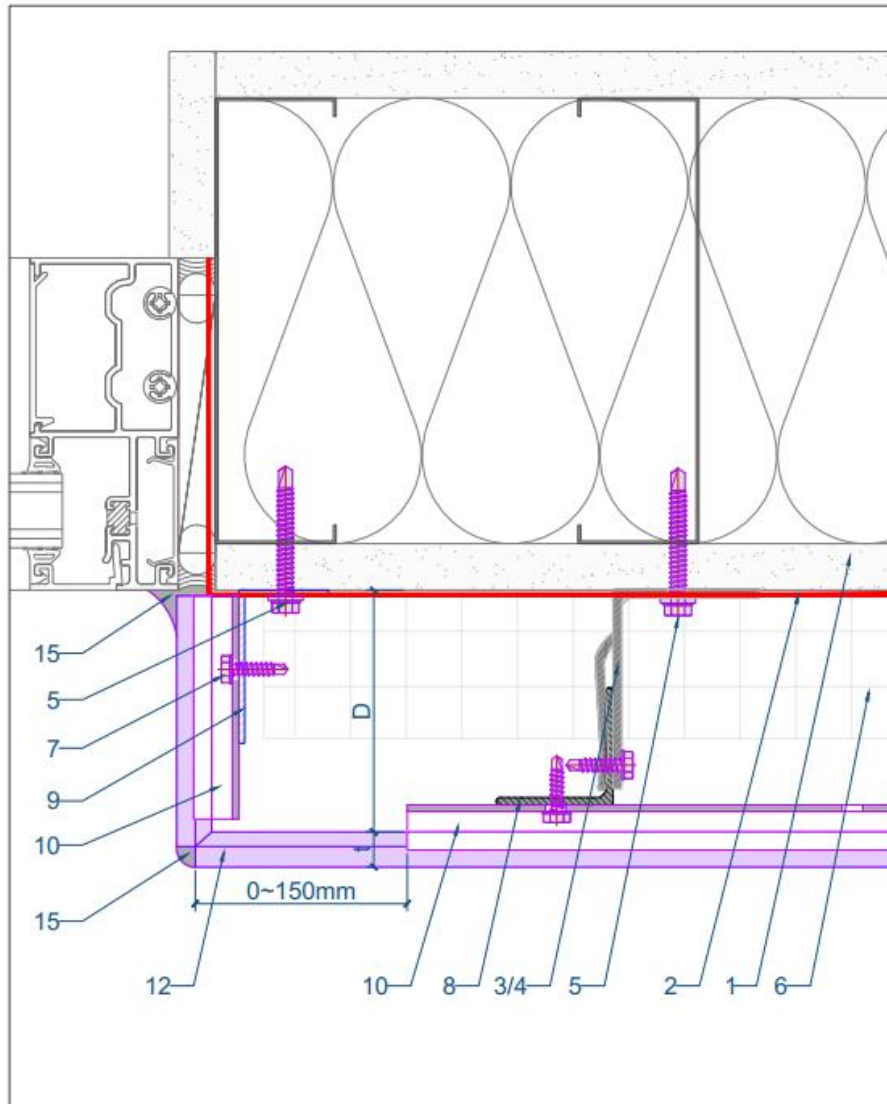

Legend

- | | | |
|--------------------------------|------------------------|------------------------------|
| 1. Exterior Wall | 9. Aluminum Angle | 17. Jamb Closure |
| 2. Vapor Barrier | 10. Clip | 18. Window Sill |
| 3. Single Bracket | 11. Starter Track | 19. Capping |
| 4. Double Bracket | 12. CladForm Panel | 20. Self-drilling Screw M4.8 |
| 5. Substrate Fastener | 13. Joint Strip | D - System depth |
| 6. Insulation | 14. Foam Strip | t - Panel thickness |
| 7. Self-drilling Screw M4.8*19 | 15. Joint Sealant | |
| 8. L-profile Rail | 16. Perforated Closure | |

Figure 9: Window Head Detail (Option 2)

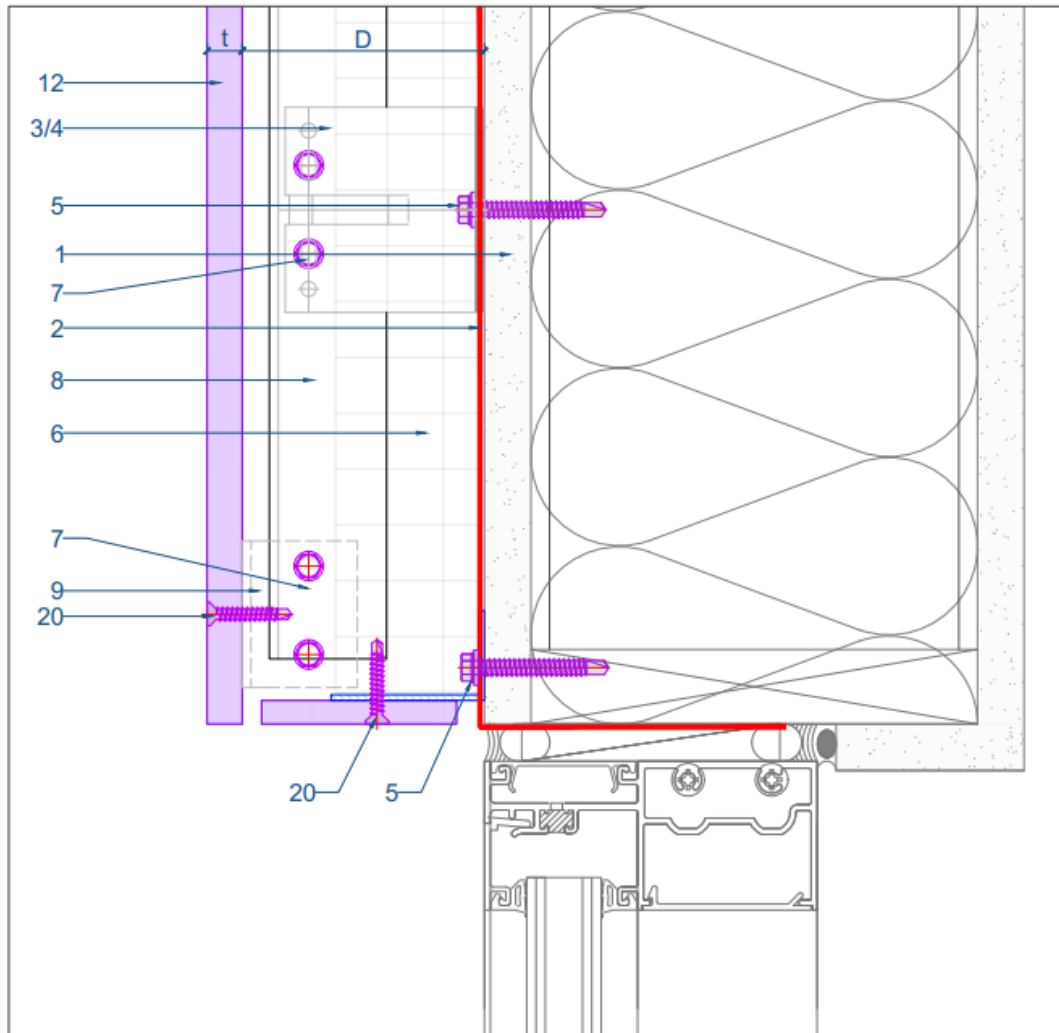

Legend

- | | | |
|--------------------------------|------------------------|------------------------------|
| 1. Exterior Wall | 9. Aluminum Angle | 17. Jamb Closure |
| 2. Vapor Barrier | 10. Clip | 18. Window Sill |
| 3. Single Bracket | 11. Starter Track | 19. Capping |
| 4. Double Bracket | 12. CladForm Panel | 20. Self-drilling Screw M4.8 |
| 5. Substrate Fastener | 13. Joint Strip | D - System depth |
| 6. Insulation | 14. Foam Strip | t - Panel thickness |
| 7. Self-drilling Screw M4.8*19 | 15. Joint Sealant | |
| 8. L-profile Rail | 16. Perforated Closure | |

Figure 10: Window Sill Detail

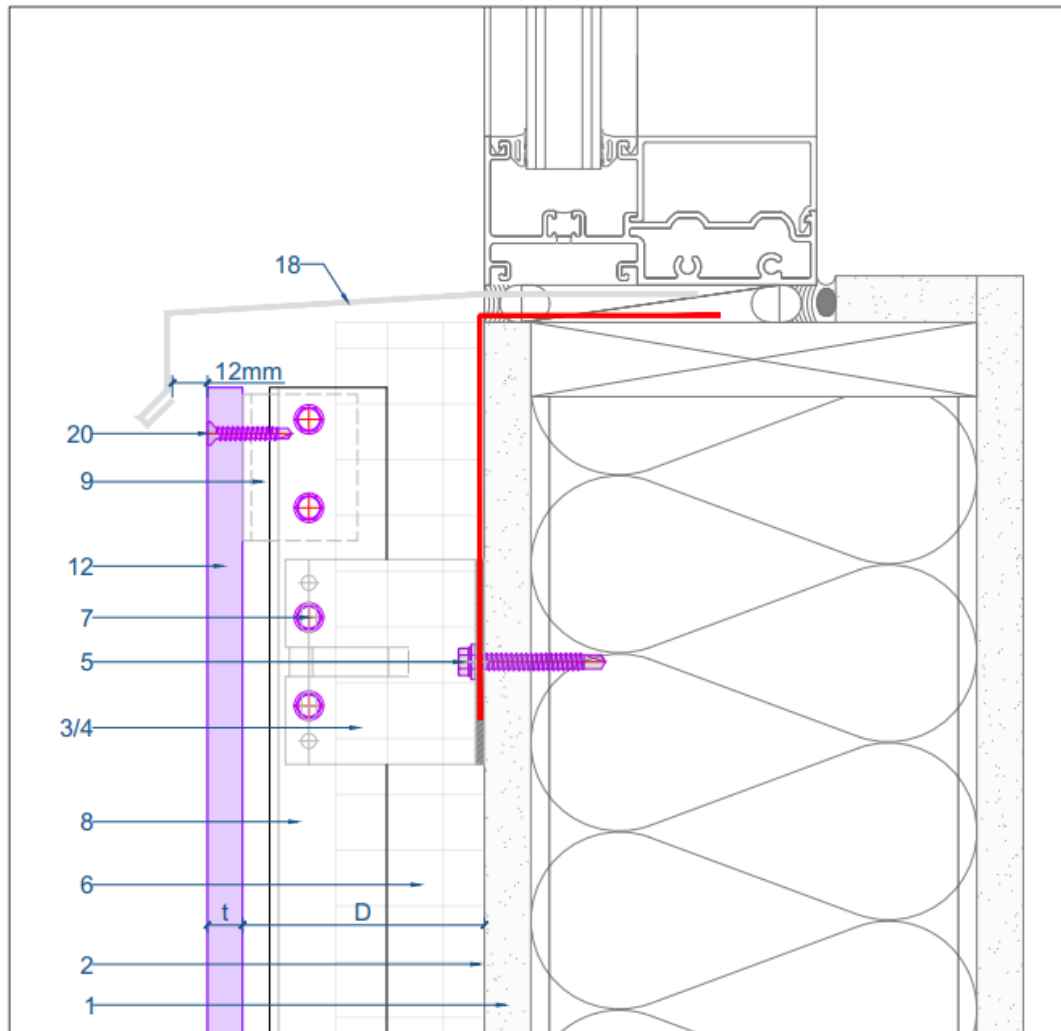

Legend

- | | | |
|--------------------------------|------------------------|------------------------------|
| 1. Exterior Wall | 9. Aluminum Angle | 17. Jamb Closure |
| 2. Vapor Barrier | 10. Clip | 18. Window Sill |
| 3. Single Bracket | 11. Starter Track | 19. Capping |
| 4. Double Bracket | 12. CladForm Panel | 20. Self-drilling Screw M4.8 |
| 5. Substrate Fastener | 13. Joint Strip | D - System depth |
| 6. Insulation | 14. Foam Strip | t - Panel thickness |
| 7. Self-drilling Screw M4.8*19 | 15. Joint Sealant | |
| 8. L-profile Rail | 16. Perforated Closure | |

Figure 11: Parapet Detail

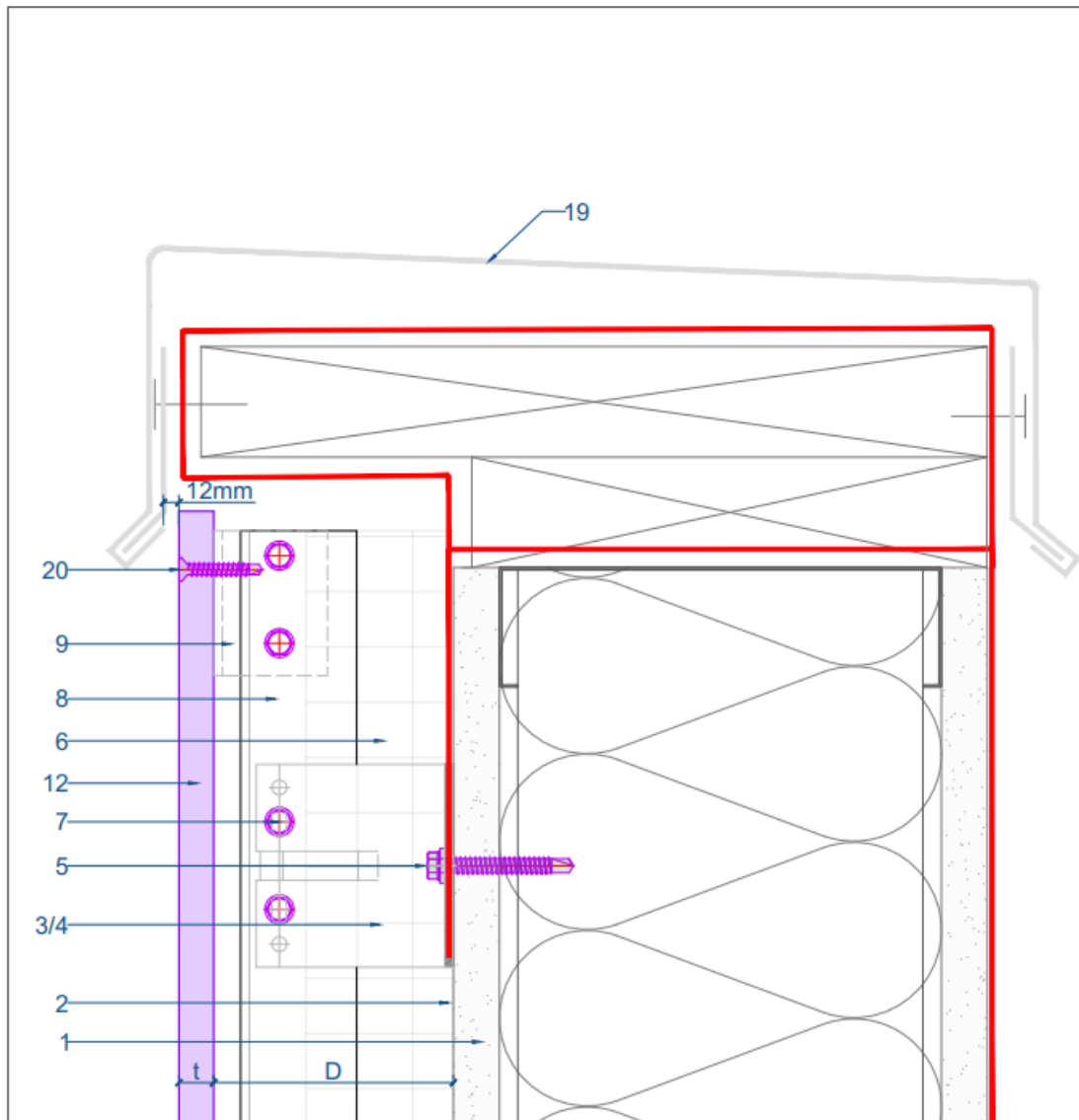

Legend

- | | | |
|--------------------------------|------------------------|------------------------------|
| 1. Exterior Wall | 9. Aluminum Angle | 17. Jamb Closure |
| 2. Vapor Barrier | 10. Clip | 18. Window Sill |
| 3. Single Bracket | 11. Starter Track | 19. Capping |
| 4. Double Bracket | 12. CladForm Panel | 20. Self-drilling Screw M4.8 |
| 5. Substrate Fastener | 13. Joint Strip | D - System depth |
| 6. Insulation | 14. Foam Strip | t - Panel thickness |
| 7. Self-drilling Screw M4.8*19 | 15. Joint Sealant | |
| 8. L-profile Rail | 16. Perforated Closure | |

Figure 12: Base Detail

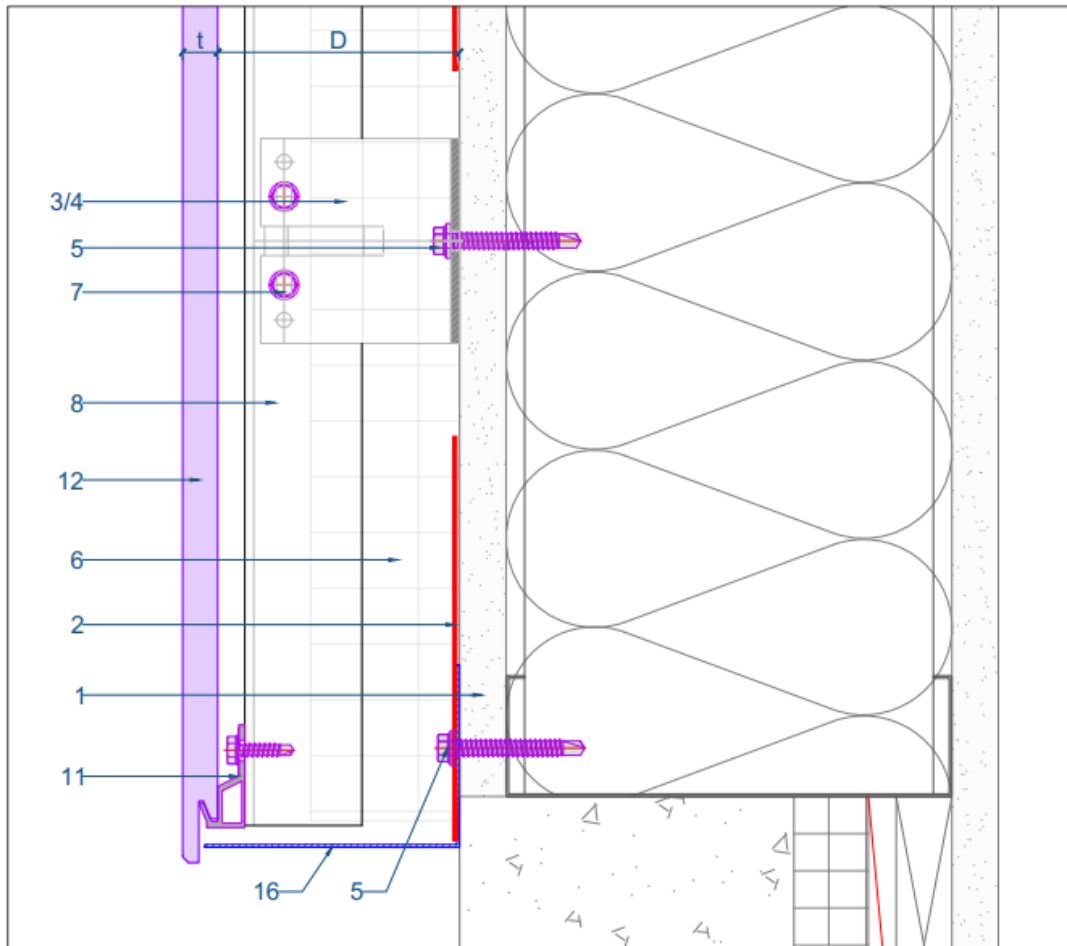

Legend

- | | | |
|--------------------------------|------------------------|------------------------------|
| 1. Exterior Wall | 9. Aluminum Angle | 17. Jamb Closure |
| 2. Vapor Barrier | 10. Clip | 18. Window Sill |
| 3. Single Bracket | 11. Starter Track | 19. Capping |
| 4. Double Bracket | 12. CladForm Panel | 20. Self-drilling Screw M4.8 |
| 5. Substrate Fastener | 13. Joint Strip | D - System depth |
| 6. Insulation | 14. Foam Strip | t - Panel thickness |
| 7. Self-drilling Screw M4.8*19 | 15. Joint Sealant | |
| 8. L-profile Rail | 16. Perforated Closure | |

Remarks

Cleaning

There are two methods of cleaning panel, mechanical cleaning and chemical cleaning. In principle, perform the cleaning of the panel over the entire surface, because partial cleaning can result in color and tonal imbalance. Normal stains can be removed with a sponge and water. Warning High Pressure Cleaning is a rough treatment of panel. Use of a high-pressure cleaner may damage the surface. Therefore, high pressure cleaning is not recommended.

Impact by Pollution and Nature

Weather and nearby vegetation may affect the appearance of the panels. Take caution to avoid pollution, dust and leaves from trees, bushes and flowers to not impact the integrity of the panels. Excessive humidity, salts, or other chemical agents can corrode the panel and attack metal.

Special Information

THE INFORMATION OR DATA IN THIS SHEET SERVES TO ENSURE THE PRODUCT'S INTENDED PURPOSE OR ITS SUITABILITY FOR USE AND IS BASED ON OUR FINDINGS AND EXPERIENCE. NEVERTHELESS, USERS ARE RESPONSIBLE FOR ESTABLISHING THE SUITABILITY OF THE PRODUCT FOR ITS INTENDED USE. APPLICATIONS OTHER THAN THOSE EXPLICITLY MENTIONED IN THIS TECHNICAL DATA SHEET ARE ONLY PERMISSIBLE AFTER PRIOR CONSULTATION WITH CHONGQING GUANJIE QIZHONG BUILDING MATERIALS CO., LTD WHERE NO APPROVAL IS GIVEN, SUCH APPLICATIONS ARE AT THE RISK OF THE USER. THIS APPLIES IN PARTICULAR WHEN THE PRODUCT IS USED IN COMBINATION WITH OTHER PRODUCTS. WHEN A NEW TECHNICAL DATA SHEET IS PUBLISHED, ALL PREVIOUS TECHNICAL DATA SHEETS ARE NO LONGER VALID.



GAJCladding CladForm GC2 System Architecture Detail

January 1st, 2025



GAJ CLADDING

FOCUSED FOR OVER 20 YEARS

Chongqing Guanjie Qizhong Building Materials Co., Ltd.
info@gajcladding.com
www.gajcladding.com